

s.6400LT actuator mounting full port 3/4" - 2" hot forged brass ball valves

More and more automation is required at all levels in our society and the s.64 **RuB** range is the answer to all needs for reliable actuated ball valve.

It features special seat design to automatically compensate for wear and it has successfully passed 100,000 cycle life tests.

Features and Specifications:

- Hot forged sand blasted, nickel plated brass body and cap sealed with Loctite or equivalent thread sealant
- Approved by GOST-R (RU), Hygenic (RU), ROSTEKHNADZOR (RU), UkrSepro (U)
- Finest brass according to EN 12165 and EN 12164 (formerly DIN 17660 and UNI 5705-65) specifications
- ISO 5211 and DIN 3337 mounting flange for universal connection to actuator,
- 100% full port for maximum flow
- 24h 100% seal test guaranteed in according to EN12266-1 RATE A
- Reinforced PTFE self-lubricating seats with flexible-lip and wear compensation design
- Dual sealing system allows valve to be operated in either direction making installation easier
- Chrome plated solid brass ball
- No metal-to-metal moving parts
- Nickel plated blowout-proof brass stem
- Two FPM O-rings at the stem for maximum safety
- No maintenance ever required
- EN 10226-1, ISO 228 parallel Female by Female threads
- Silicone-free lubricant on all seals
- 40 bar (Kg/cm²) non-shock cold working pressure (Delta P max permissible 16 bar)
- Range: -20°C +170°C temperature (Warning: freezing of the fluid in the installation may severely damage the valve)



Options:

- Special valve configurations available upon request,
- s.64 configuration featuring NPT taper ANSI B.1.20.1 Female by Female threads, unplated body, reinforced seats and brass or stainless stem,
- Rack and pinion pneumatic actuator (spring return or double acting)
- Compact power electric actuator

Approved By:



NOTE: Approvals apply to specific configurations only.

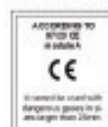

You can purchase the valve alone or with the RuB actuator already mounted.



Quick assembly of pneumatic actuator with spring ring



Assembly of pneumatic actuator with M5 nuts

Technical Specifications:

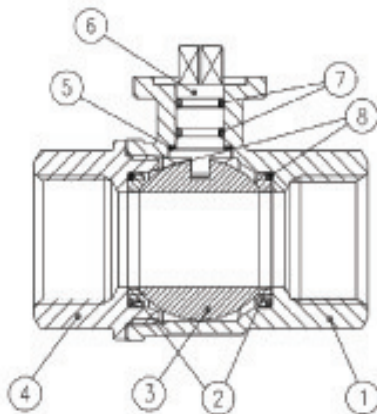

Ball valves are marked
CE on body from
1.1/4" to 2", as follow

CE S6400A
Cat. 1 - A

PART DESCRIPTION	Q.ty	Material
1 Nickel plated body	1	CW617N
2 Ball seat	2	Ptfe carbographite filled
3 Chrome plated ball	1	CW617N
4 Nickel plated end cap	1	CW617N
5 Washer	1	Ptfe carbon filled 25%
6 Nickel plated stem O-Ring design	1	CW617N
7 O-Ring	2	FPM
8 O-Ring	2	FPM

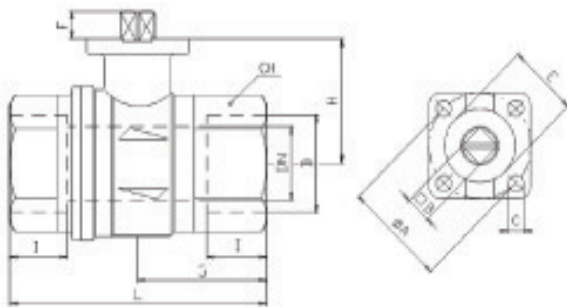

Ball seats and Stem configuration of valves over 2" is different.
Ask for details at our Service Center..

Ask for additional information on the whole range of RuB valves
and consult with your supplier for special applications.

Torque for Actuator Sizing N.m

Delta P →	0 + 6 Bar		>6 + 16 Bar	
	To open	To close	To open	To close
3/4"	1,5	1,5	2,4	2,4
1"	2,2	2,2	3,5	3,5
1.1/4"	2,5	2,5	4	4
1.1/2"	5,8	5,8	9,5	9,5
2"	7,9	7,9	13	13

Torque correction factors

Valve torque can vary according to operating frequency, temperature,
and friction characteristics of the media.
If media has more or less friction than water,
multiply torque by the following factors.

Lubricating oils or liquids 0.8

Dry gases, superheated steam 1.5

Slurries or liquids bearing abrasive particles 1.5-2.5

For other conditions please inquire of your RuB representative or distributor.

Pressure - Temperature Chart

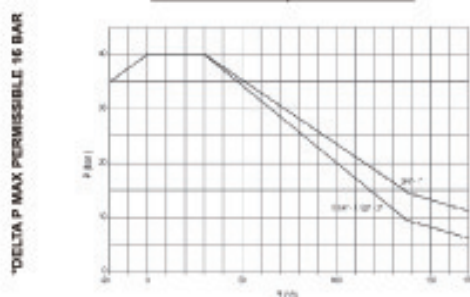

Pressure Drop Chart

